

Cut sheet CTM-RU

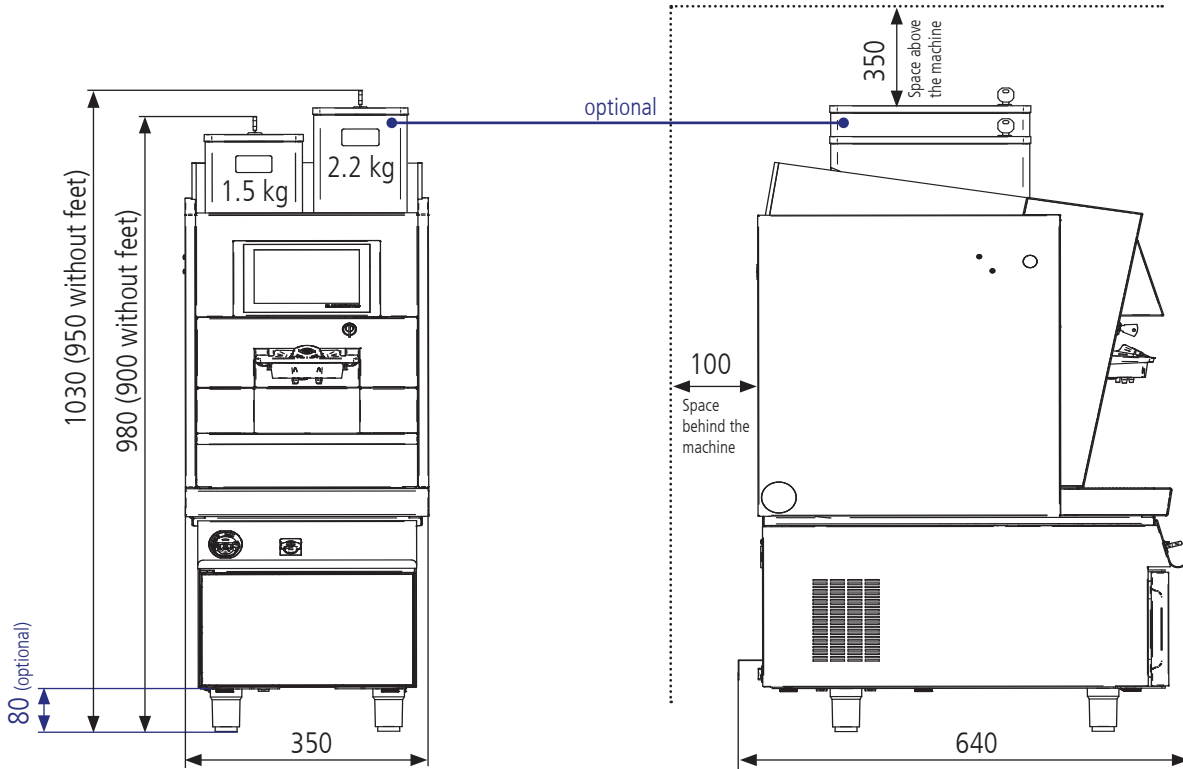

Automatic coffee machine Black&White 3 CTM-RU	
Connection	220-240 VAC   13A   50-60 Hz
Output	2400-2900 W
Dimensions	350 x 640 x 980 (1030) mm (W / D / H)
Coffee spout height standard	80-173 mm
Weight	77.5 kg

Drainage

The distance between the drain and the machine must not be more than 40 in. Make sure there is no dip or any back pressure in the drain hose. The end of the hose must not be in the water.

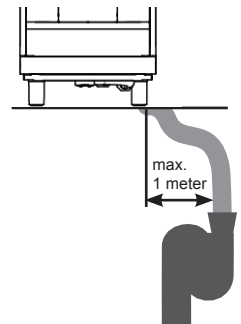

Water connection	3/8"
Water pressure	2-4 bar / 30-60 psi
Chlorine	none
TDS	70-200 ppm
Hardness	5-8 °dH (8-14 °fH)
pH	6.8-7.4
Alkalinity	less than 100 ppm
Iron	less than 0.25 ppm

Conversion table water hardness:

Water hardness	GE	FR	EN	Ppm	Mval/l
1° dH	1.0	1.79	1.25	17.8	0.357
1° fH	0.56	1.0	0.7	10.0	0.2
1° e	0.8	1.43	1.0	14.3	0.86
1° ppm	0.056	0.1	0.07	1.0	0.02
1 mval/l	2.8	5.0	3.5	50.0	1.0

For more information see Technical Manual.

Hole diameter 70 mm for water inlet / outlet and electric cords (if going through the bottom of the refrigerator).

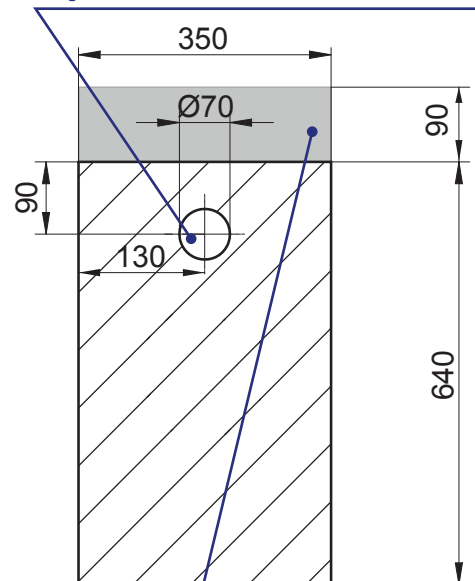

Hole diameter 70 mm for water inlet / outlet and electric cords (if going through the back of the machine).